

08	4	1	1	3
	4	2	1	1
	4	8	2	4
	EN 1154:1996 + A1:2002			
0432-CPD-0067	Substance:---			

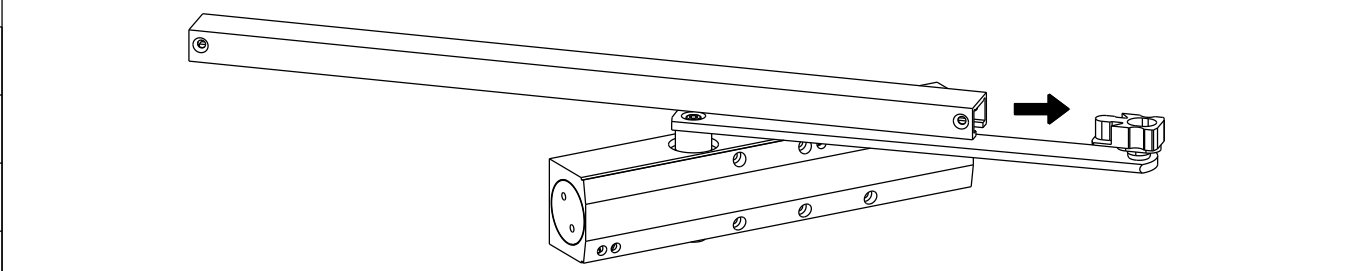
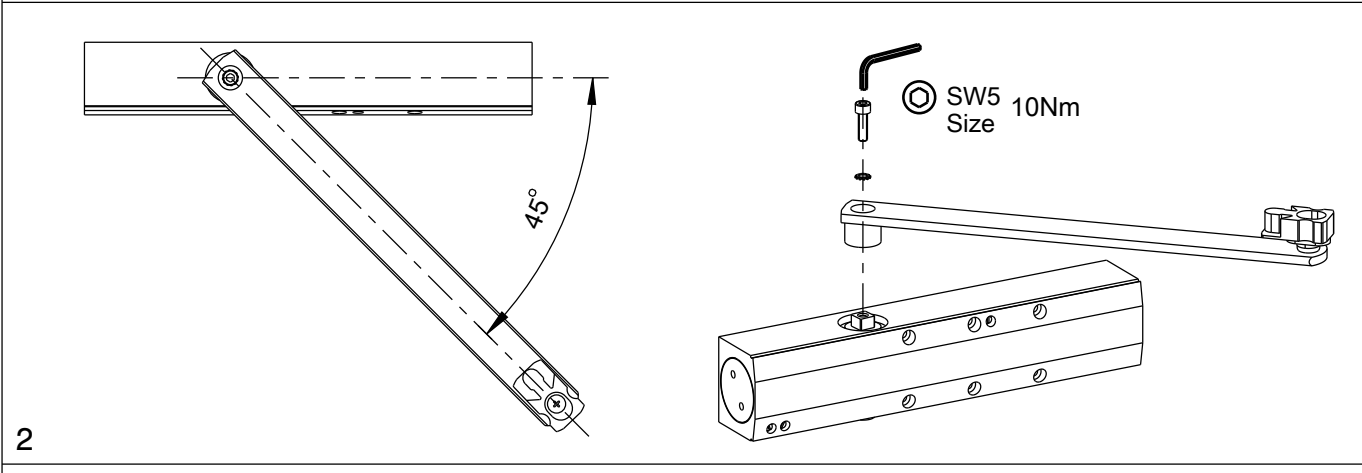
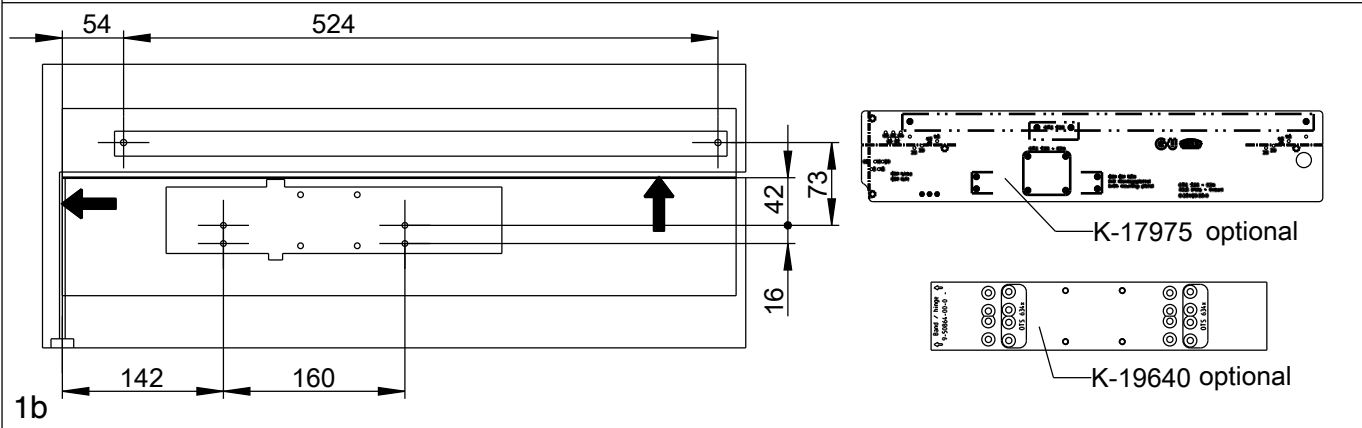
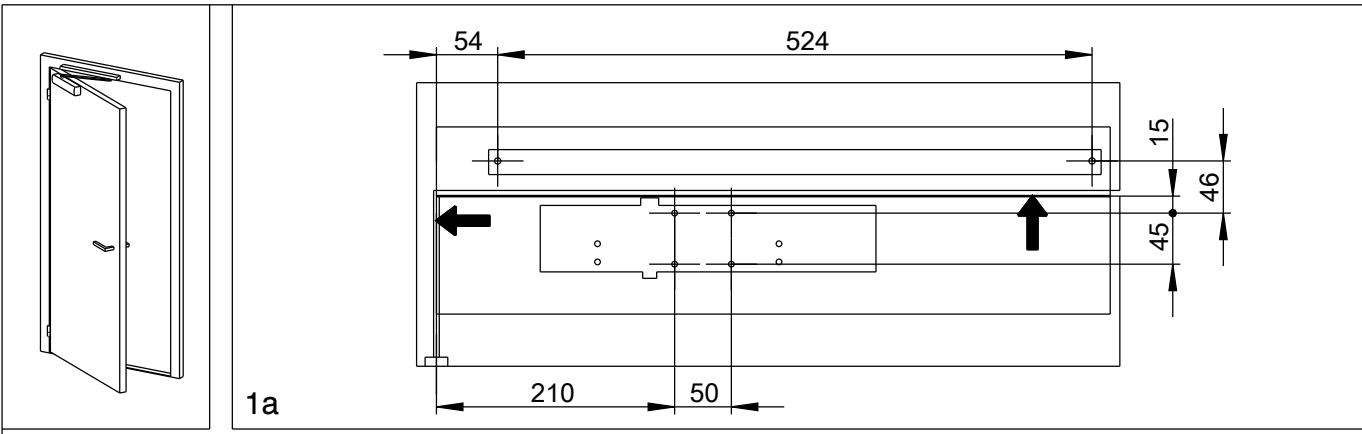

HINWEIS / NOTE

Die Produktinformation Türschließer OTS/UTS/VTS (Art.-Nr. 0-46884-P0-0-0) finden Sie auf der GU-Homepage "www.g-u.com/de/service/downloads.html".

You will find the product information 0-46884-P0-0-0 "OTS/UTS/VTS -Door closer" at the GU-Homepage www.g-u.com under "SERVICES" in the menu item "Downloads".

Leistungserklärungen finden Sie auf der GU-Homepage "www.g-u.com/de/service/bauproduktenverordnung.html".

Declarations of Performance can be found at the GU-Homepage "www.g-u.com/en/services/construction-products-regulation.html".

Description
OTS 634 Normalmontage Bandseite, DIN links K-17523
OTS 634 standard mounting on hinge side, DIN left K-17523

	Release No. --	Level	Released		Scale %	Modification 7	Size 4
	Mod. No. G34938	Ver.	--	Wi		Drawing No. 0-44860-PL-0-0	Sheet 1/12
	Replacement for --	Draft	20.02.2018	Se			

Proprietary rights apply in accordance with ISO 16016.

EN
ES
FR
--
--

Montageanleitung
assembly instructions
V5

4a

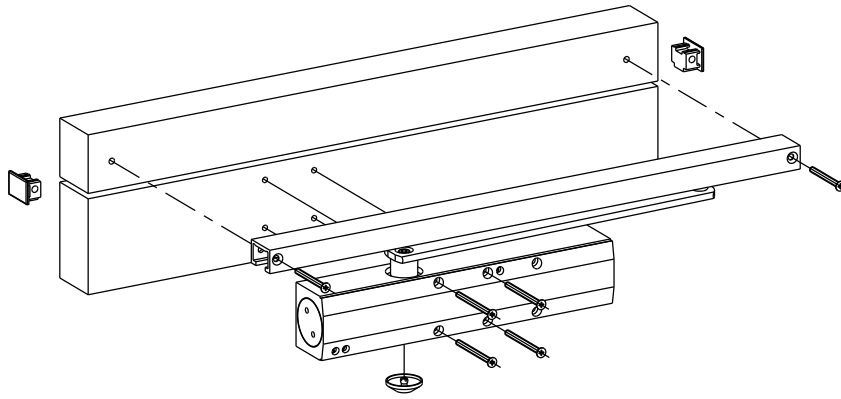

4b

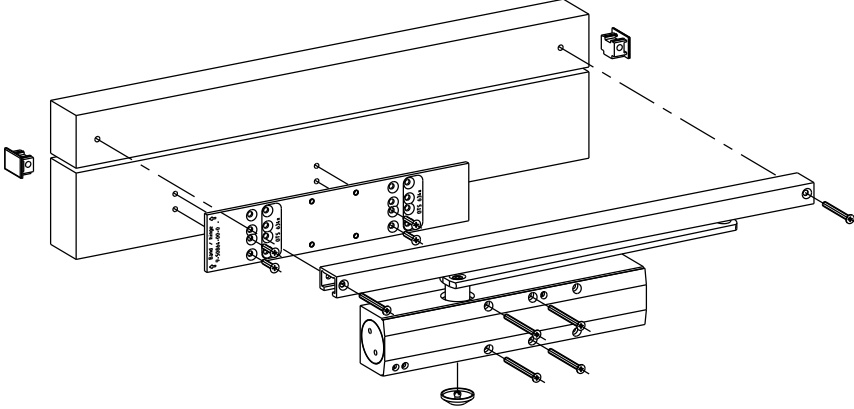

5

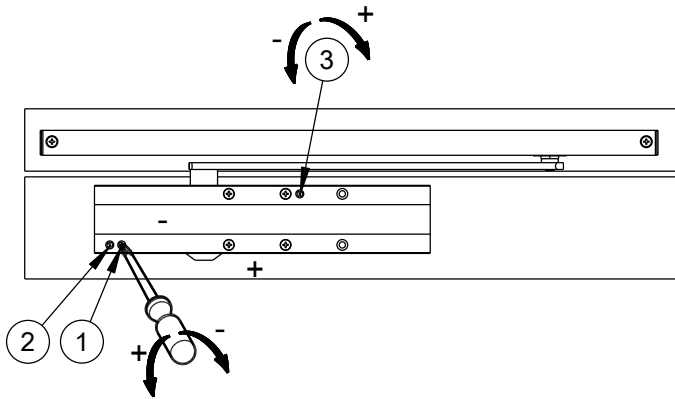

- ① Schließgeschwindigkeit
Closing speed
- ② Türenschlag
Latching force
- ③ Öffnungsdämpfung
Backcheck

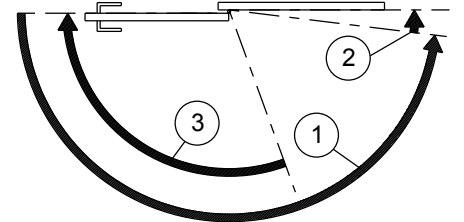

6

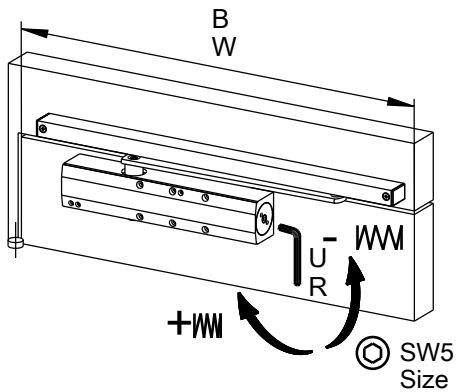

Schließkraft Closing force		
EN	≤ B W	U R
2	850mm	- 10
3	950mm	- 8
4	1100mm	0

7

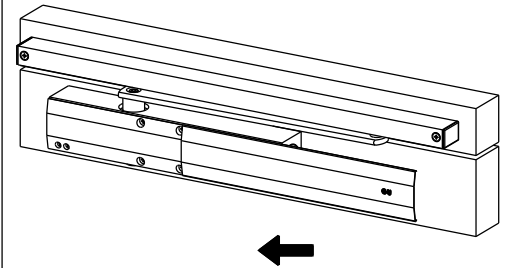

- EN
- ES
- FR
-
-

Description

OTS 634 Normalmontage Bandseite, DIN links K-17523

OTS 634 standard mounting on hinge side, DIN left K-17523

Montageanleitung
assembly instructions
V5

	Release No. --	Level	Released		Scale %	Modification 7	Size 4
	Mod. No. G34938	Ver.	--	Wi		Drawing No. 0-44860-PL-0-0	Sheet 2/12
	Replacement for --	Draft	20.02.2018	Se			

Proprietary rights apply in accordance with ISO 16016.

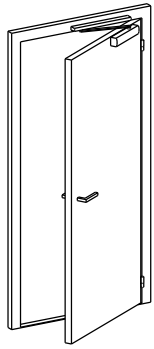

1a

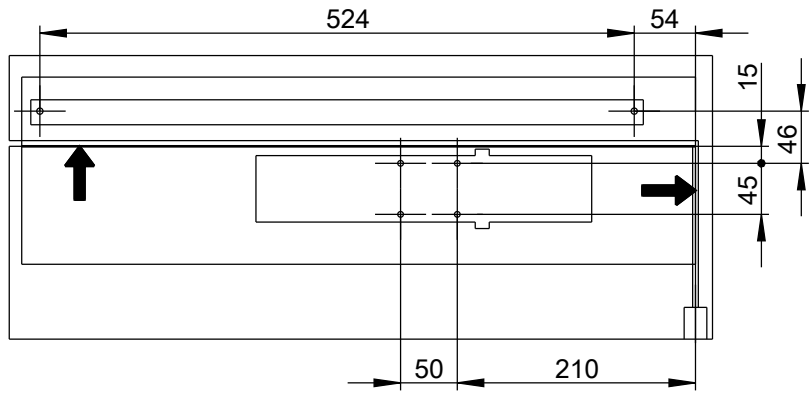

1b

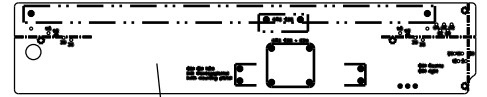
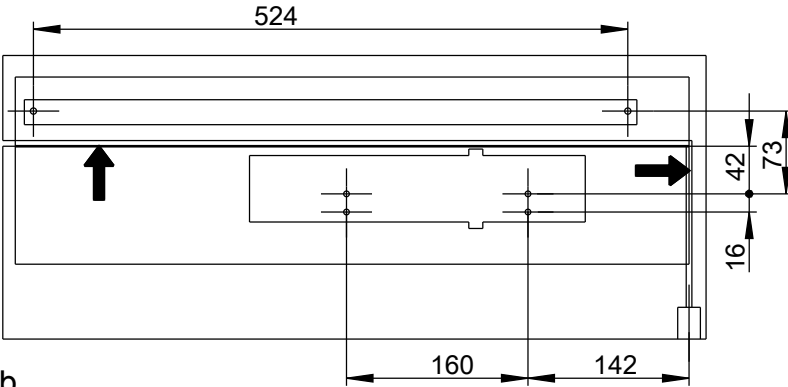

K-17975 optional

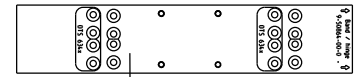

K-19640 optional

Proprietary rights apply in accordance with ISO 16016.

2

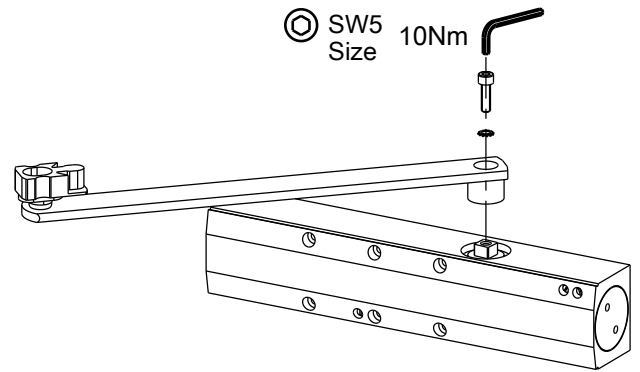
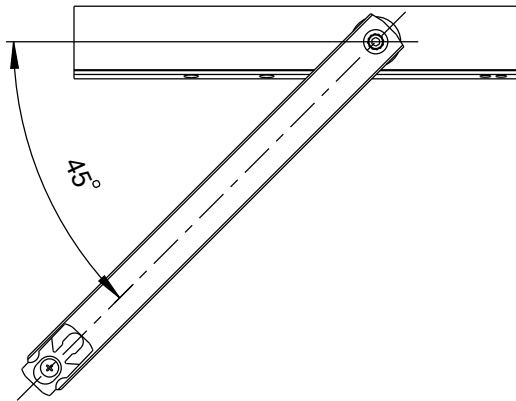

- EN
- ES
- FR
-
-

3

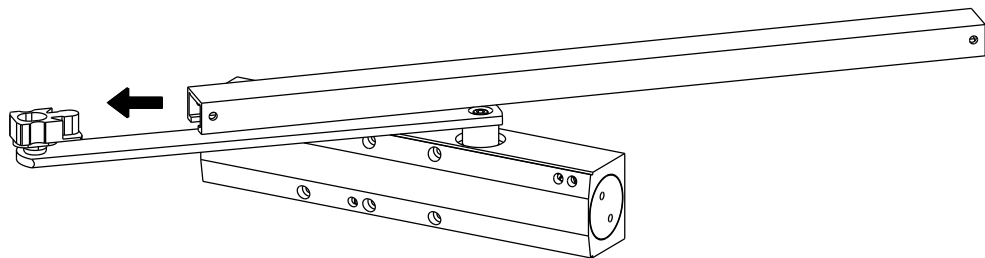

Description

OTS 634 Normalmontage Bandseite, DIN rechts K-17523

OTS 634 standard mounting on hinge side, DIN right K-17523



Release No.
--
Mod. No.
G34938

Replacement for --

Level	Released	
Ver.	--	Wi
Draft	20.02.2018	Se

Scale
%

Modification
7

Drawing No.

0-44860-PL-0-0

Size
4

Sheet

3/12

4a

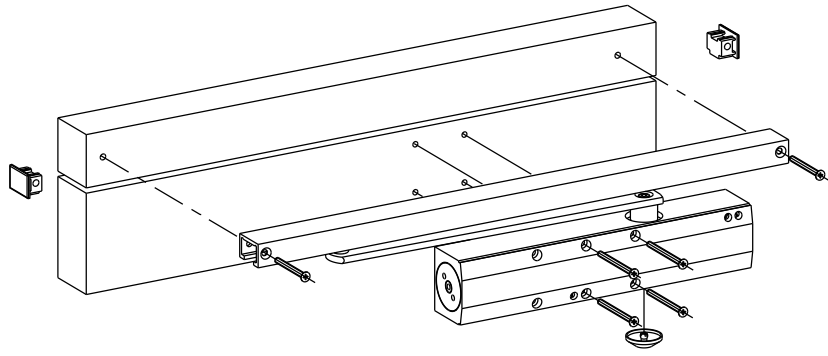

4b

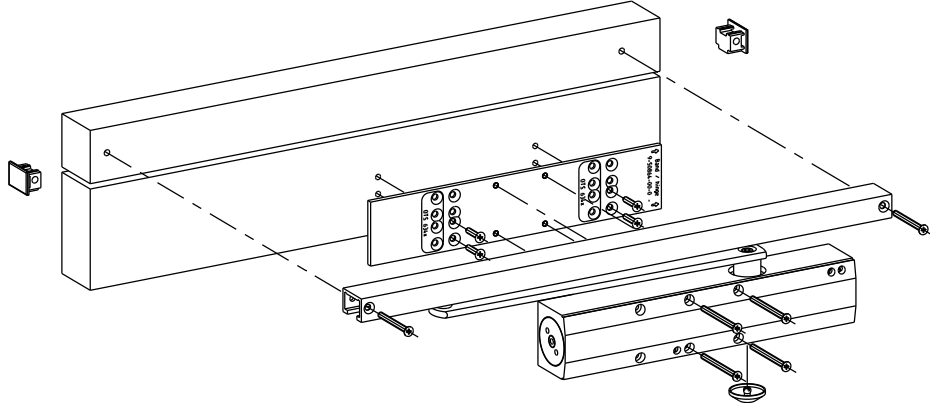

5

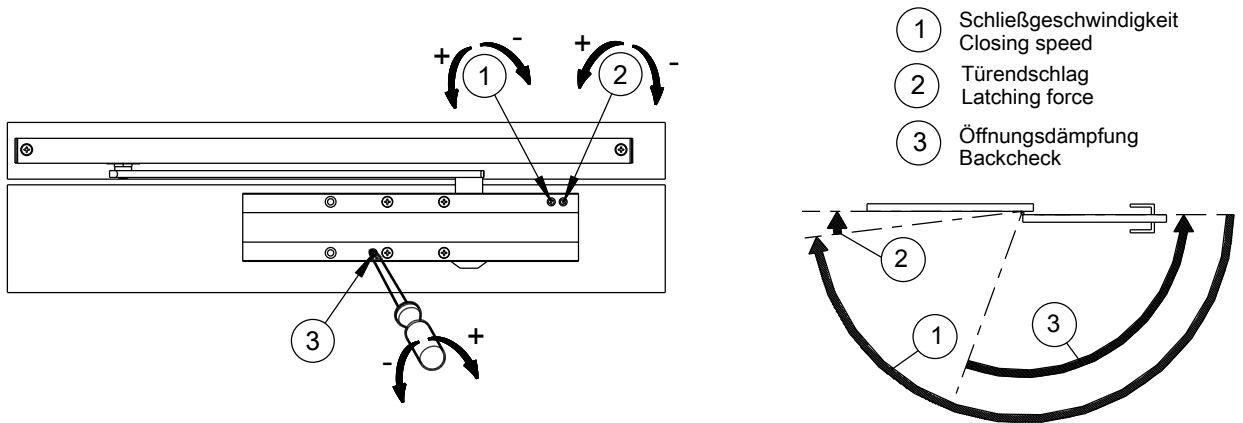

6

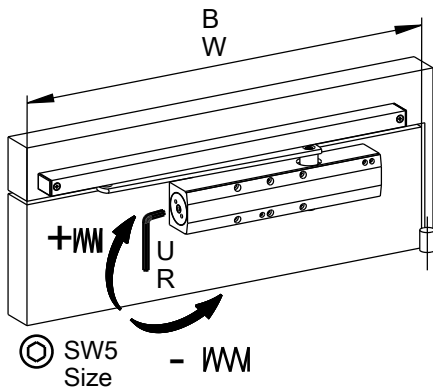

Schließkraft Closing force		
EN	$\leq \frac{B}{W}$	$\frac{U}{R}$
2	850mm	- 10
3	950mm	- 8
4	1100mm	0

7

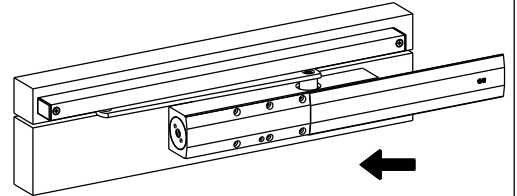

- EN
- ES
- FR
-
-

Montageanleitung
assembly instructions
V5

Description

OTS 634 Normalmontage Bandseite, DIN rechts K-17523

OTS 634 standard mounting on hinge side, DIN right K-17523

	Release No. --	Level	Released		Scale %	Modification 7	Size 4
	Mod. No. G34938	Ver.	--	Wi		Drawing No. 0-44860-PL-0-0	Sheet 4/12
	Replacement for --	Draft	20.02.2018	Se			

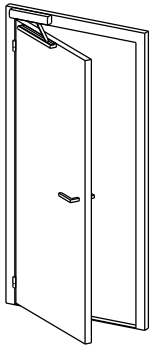

1a

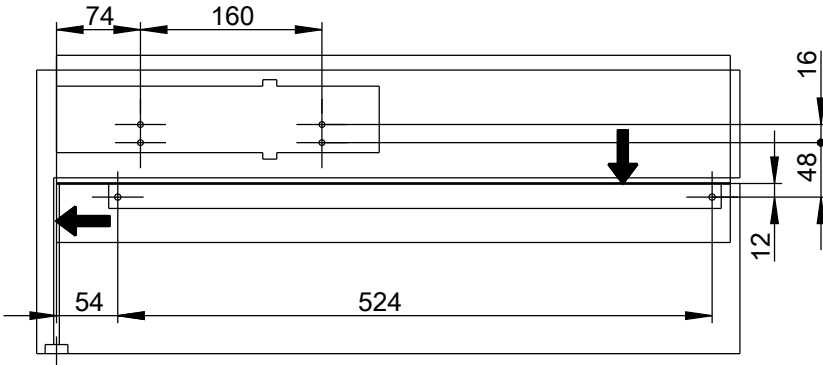
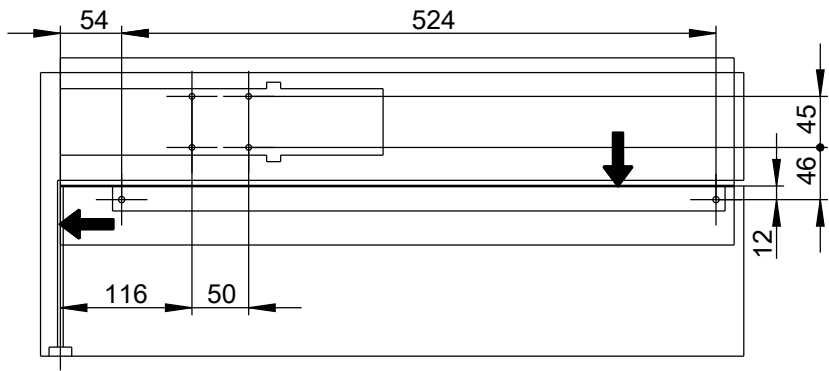

1b

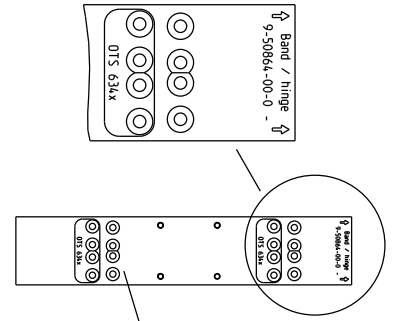

K-19640 optional

Proprietary rights apply in accordance with ISO 16016.

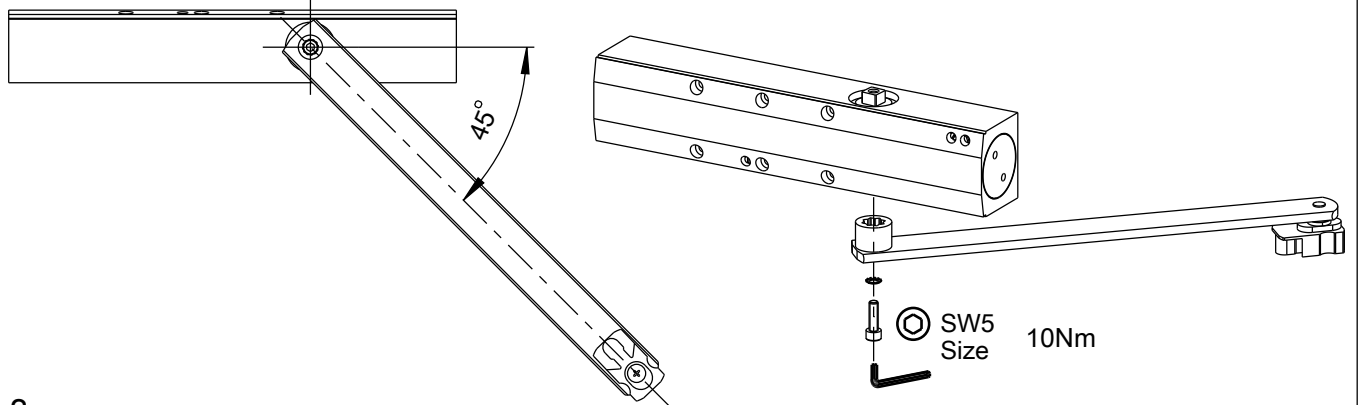

2

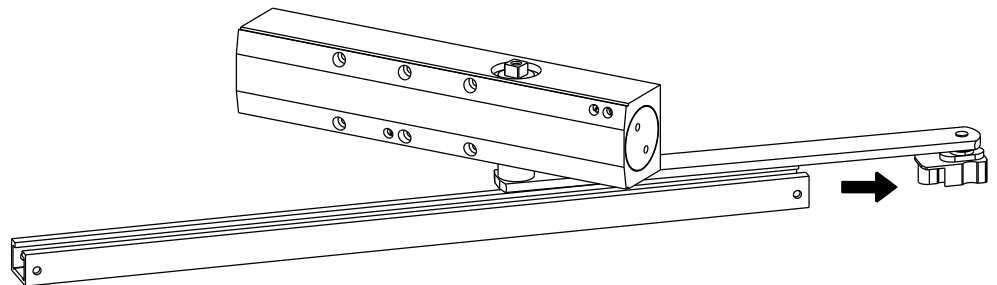

3

Description

OTS 634 Kopfmontage Bandseite, DIN links K-17523

OTS 634 transom mounting on hinge side, DIN left K-17523

- EN
- ES
- FR
-
-

Montageanleitung
assembly instructions
V5



Release No.
--
Mod. No.
G34938

Level	Released	
Ver.	--	Wi
Draft	20.02.2018	Se

Scale
%

Modification
7

Drawing No.

0-44860-PL-0-0

Size
4

Sheet

5/12

Replacement for --

4a

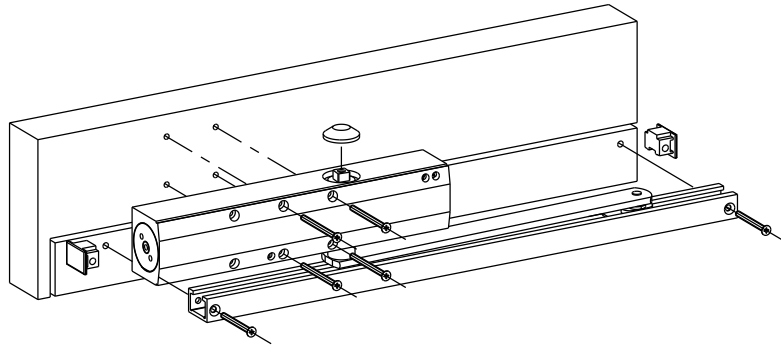

4b

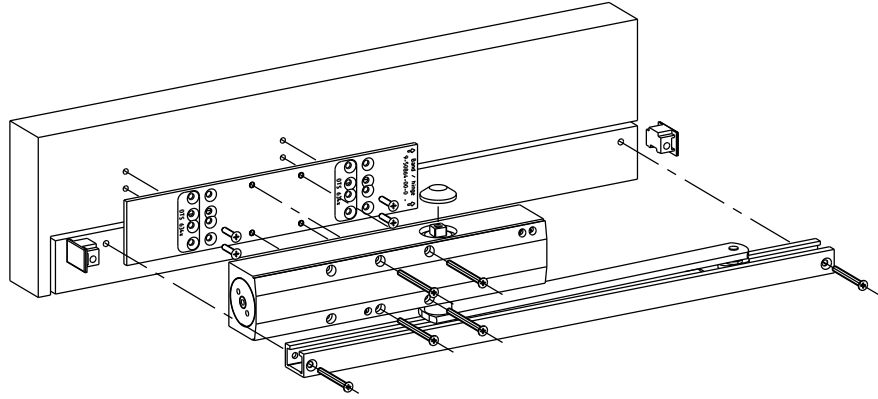

Proprietary rights apply in accordance with ISO 16016.

5

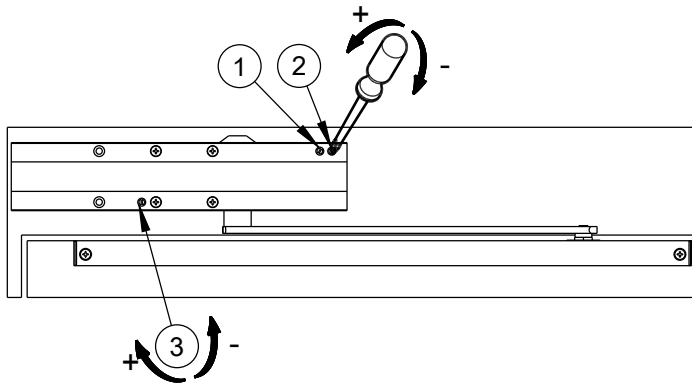

- ① Schließgeschwindigkeit
Closing speed
- ② Türendschlag
Latching force
- ③ Öffnungsdämpfung
Backcheck

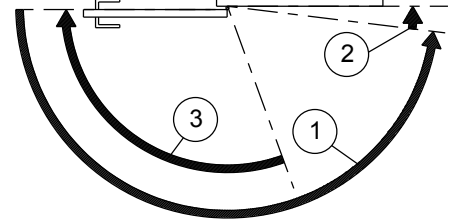

EN
ES
FR
--
--

6

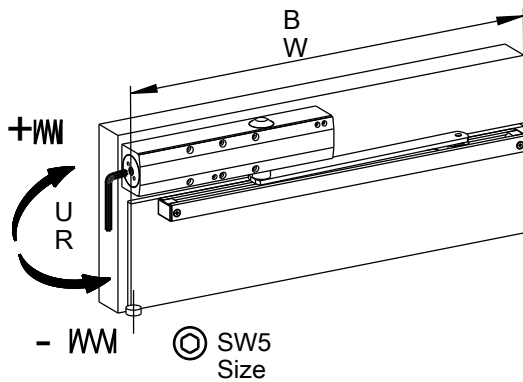

Schließkraft Closing force		
EN	≤ B W	U R
2	850mm	- 10
3	950mm	- 8
4	1100mm	0

7

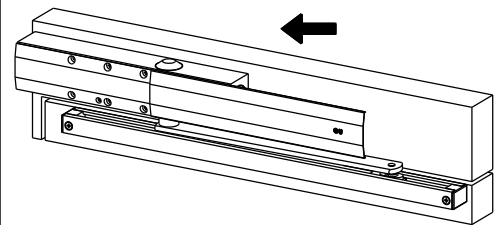

Montageanleitung
assembly instructions
V5

Description

OTS 634 Kopfmontage Bandseite, DIN links K-17523

OTS 634 transom mounting on hinge side, DIN left K-17523

	Release No. --	Level	Released		Scale %	Modification 7	Size 4
	Mod. No. G34938	Ver.	--	Wi		Drawing No. 0-44860-PL-0-0	Sheet 6/12
	Replacement for --	Draft	20.02.2018	Se			

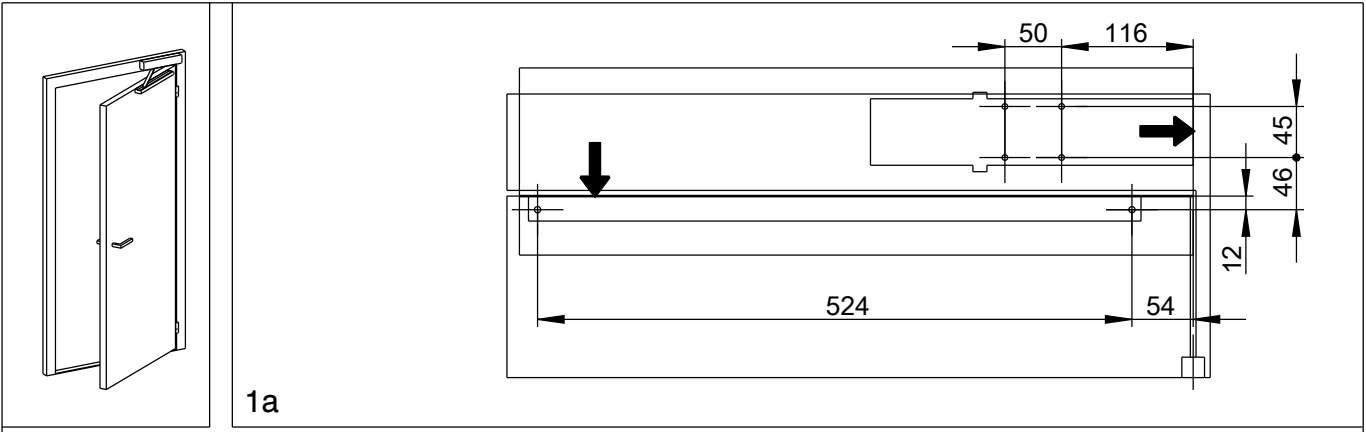

1a

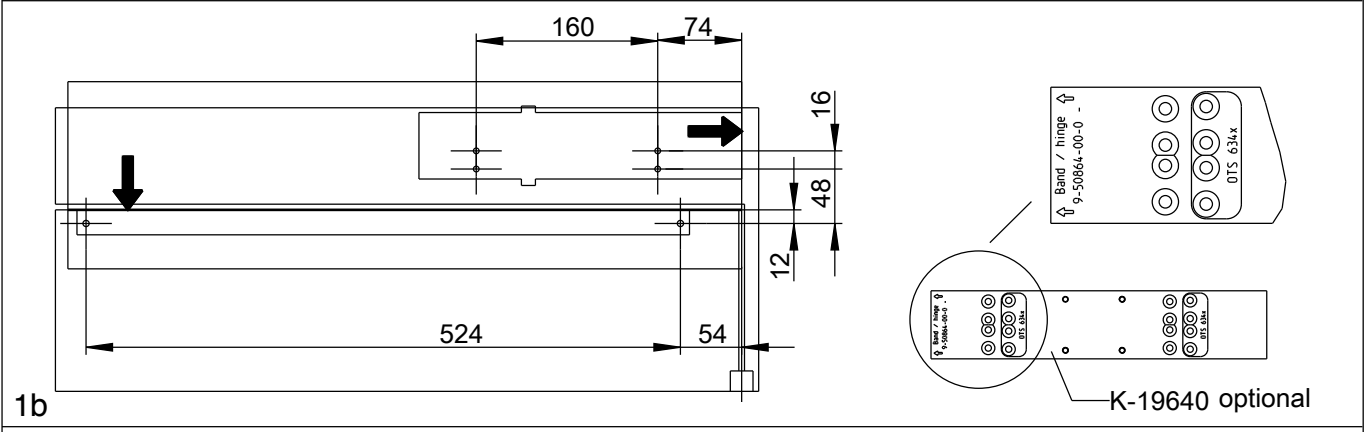

1b

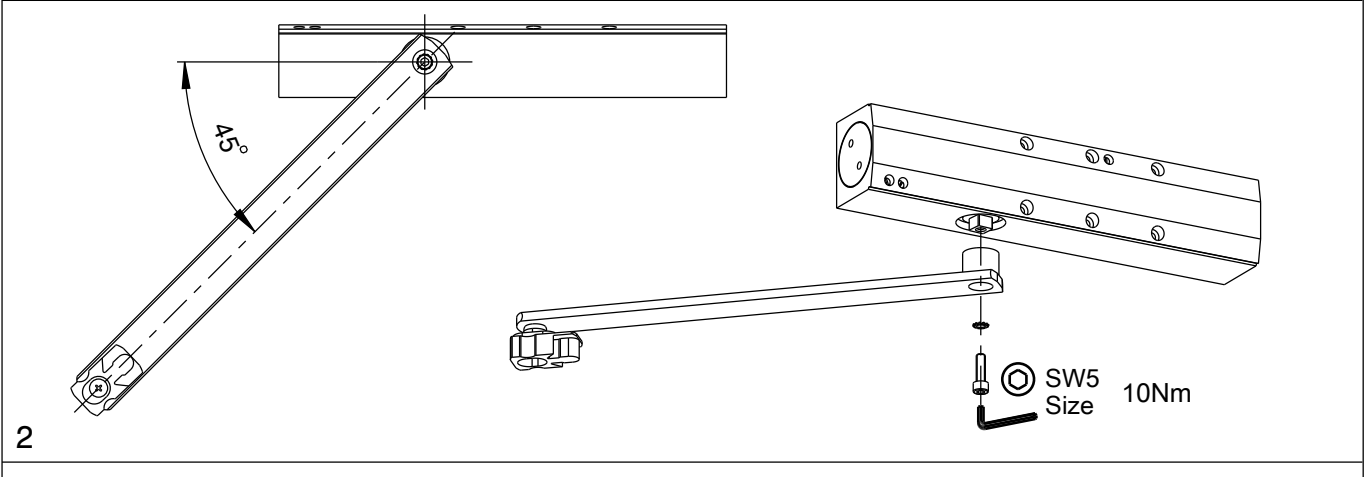

2

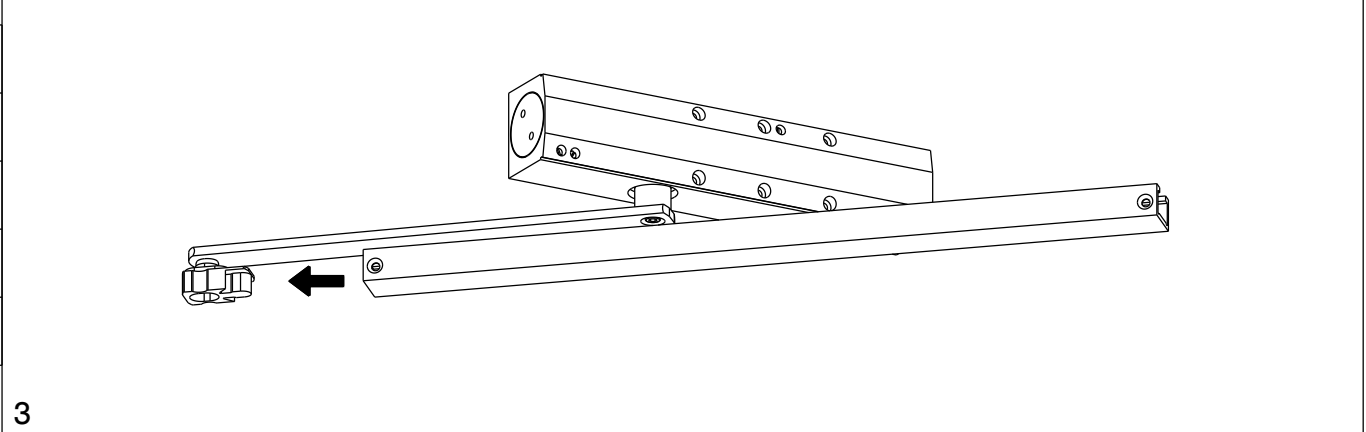

3

Description
 OTS 634 Kopfmontage Bandseite, DIN rechts K-17523
 OTS 634 transom mounting on hinge side, DIN right K-17523

- EN
- ES
- FR
-
-

Montageanleitung
 assembly instructions
 V5

	Release No. --	Level	Released		Scale %	Modification 7	Size 4
	Mod. No. G34938	Ver.	--	Wi		Drawing No.	Sheet
	Replacement for --	Draft	20.02.2018	Se		0-44860-PL-0-0	7/12

Proprietary rights apply in accordance with ISO 16016.

4a

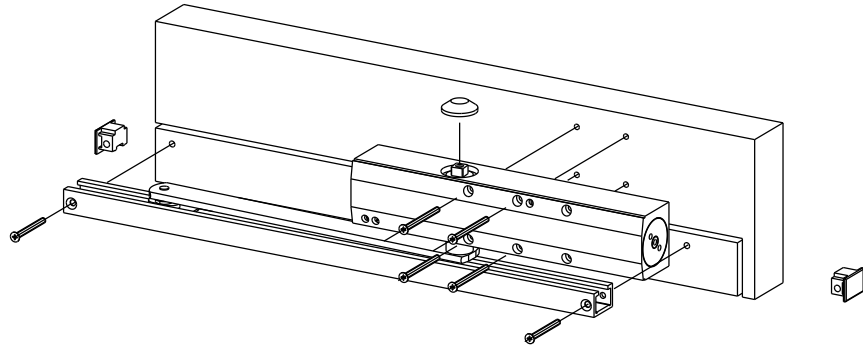

4b

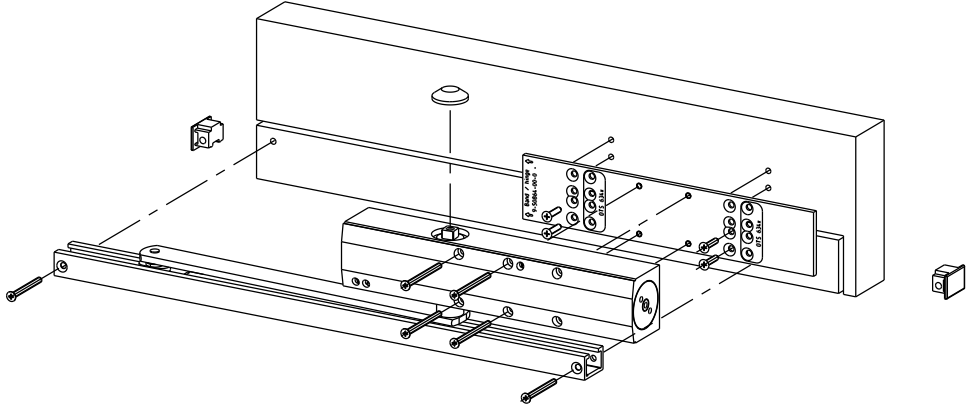

Proprietary rights apply in accordance with ISO 16016.

5

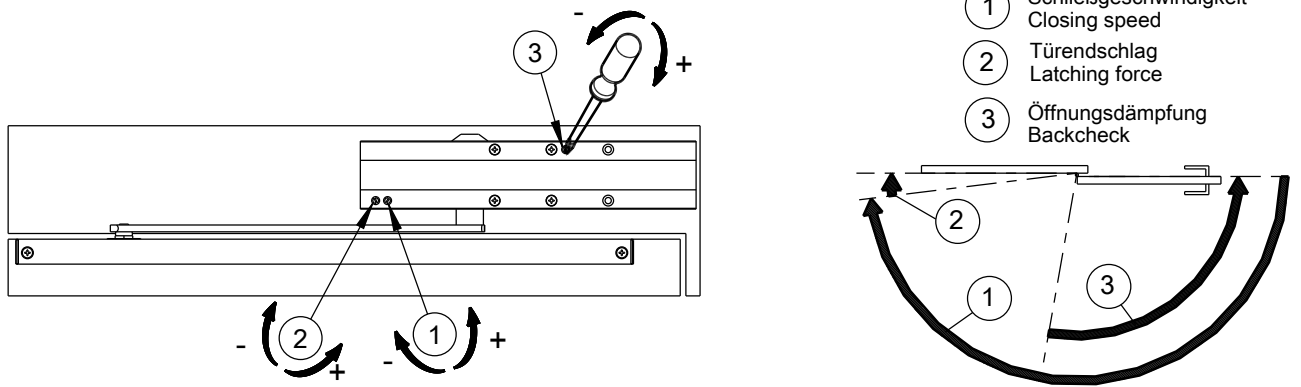

EN
ES
FR
--
--

6

Schließkraft Closing force		
EN	≤ B W	U R ↻
2	850mm	- 10
3	950mm	- 8
4	1100mm	0

⊙ SW5 Size

7

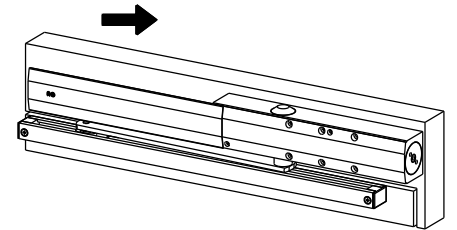

Description

OTS 634 Kopfmontage Bandseite, DIN rechts K-17523

OTS 634 transom mounting on hinge side, DIN right K-17523

Montageanleitung
assembly instructions
V5

	Release No. --	Level	Released		Scale %	Modification 7	Size 4
	Mod. No. G34938	Ver.	--	Wi		Drawing No. 0-44860-PL-0-0	Sheet 8/12
	Replacement for --	Draft	20.02.2018	Se			

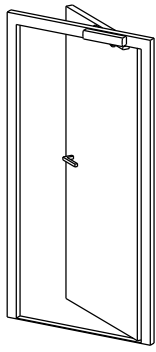

1a

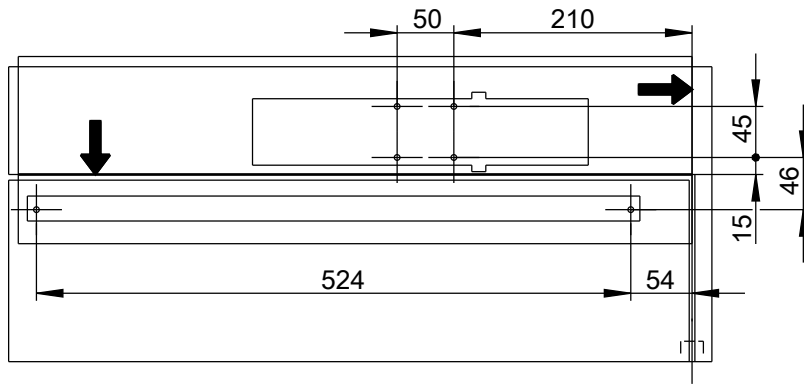

1b

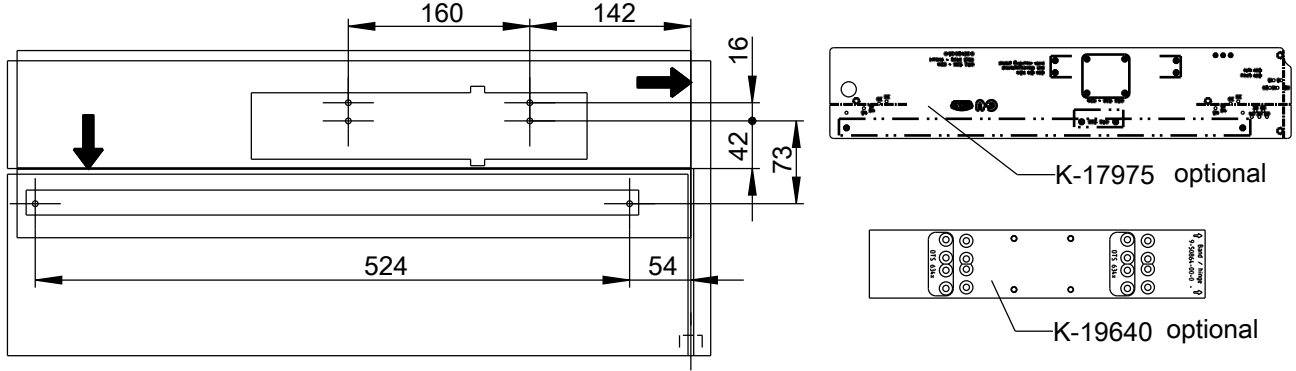

Proprietary rights apply in accordance with ISO 16016.

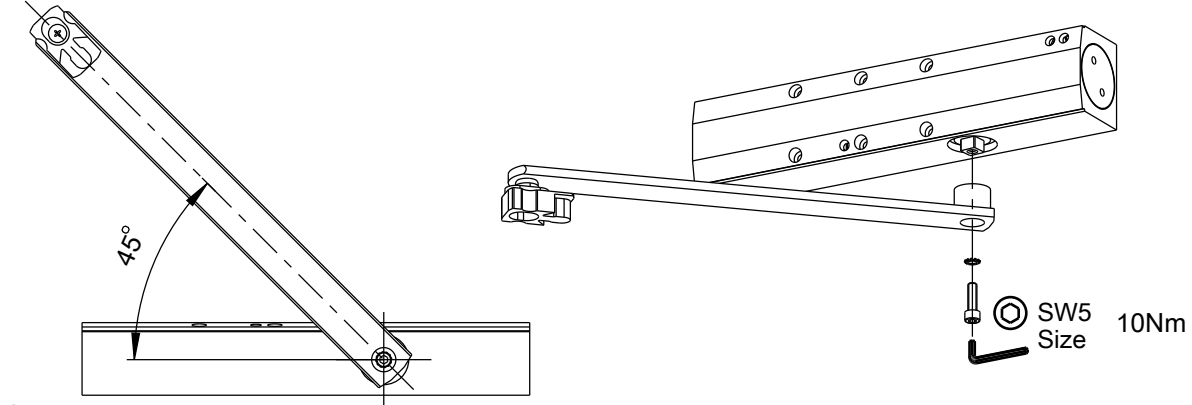

2

- EN
- ES
- FR
-
-

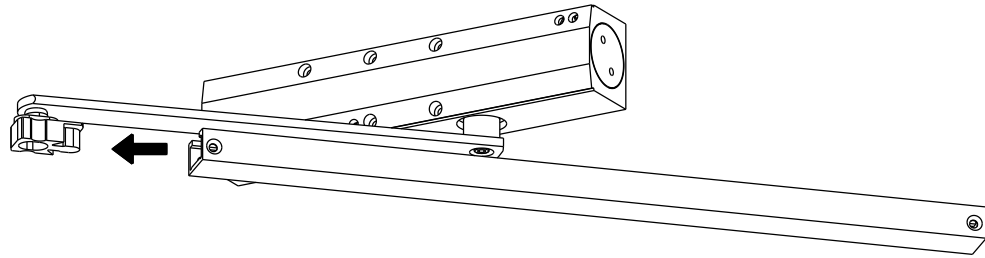

3

Description

OTS 634 Kopfmontage Bandgegenseite, DIN links K-17523
 OTS 634 transom mounting on side opposite to hinges, DIN left K-17523



Release No. --	Level	Released		Scale %	Modification 7	Size 4
	Ver.	--	Wi			
	Mod. No. G34938	Draft	20.02.2018		Se	Drawing No. 0-44860-PL-0-0
Replacement for --						

Montageanleitung
assembly instructions
V5

4a

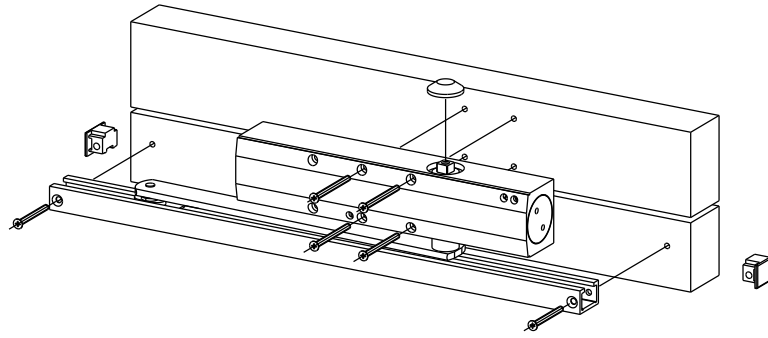

4b

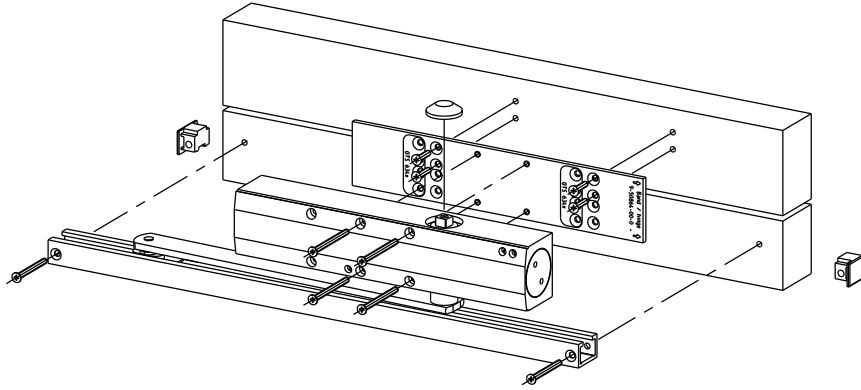

Proprietary rights apply in accordance with ISO 16016.

5

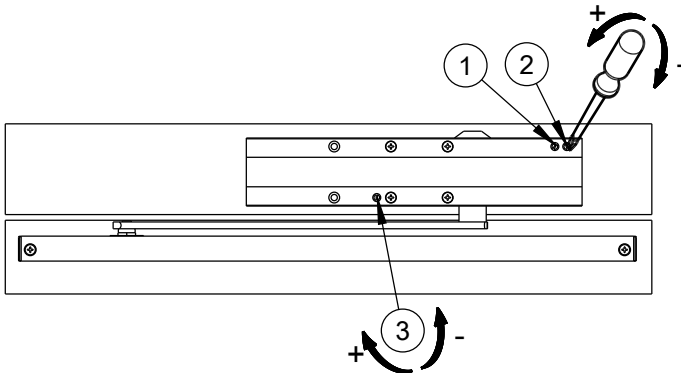

- ① Schließgeschwindigkeit
Closing speed
- ② Türens Schlag
Latching force
- ③ Öffnungsdämpfung
Backcheck

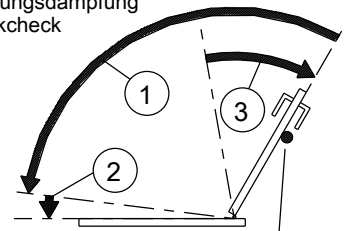

Türstopper bauseits setzen
Door stop to be provided by customer
max. 105°

- EN
- ES
- FR
-
-

6

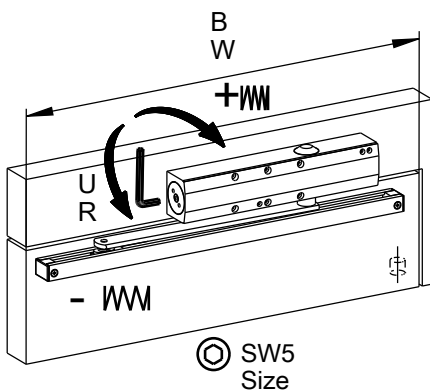

Schließkraft Closing force		
EN	≤ B W	U R
2	850mm	- 10
3	950mm	- 8
4	1100mm	0

7

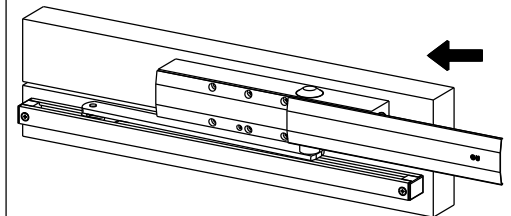

Description

OTS 634 Kopfmontage Bandgegenseite, DIN links K-17523

OTS 634 transom mounting on side opposite to hinges, DIN left K-17523

Montageanleitung
assembly instructions
V5



Release No.
--
Mod. No.
G34938

Level	Released	
Ver.	--	Wi
Draft	20.02.2018	Se

Scale
%

Modification
7

Size
4

Drawing No.

0-44860-PL-0-0

Sheet

10/12

Replacement for --

08	1	3
	4	1
	2	8
	3	8
Gretsch-Unitas GmbH Baubeschläge Johann-Maus-Str. 3 D-71254 Ditzingen		
EN 1154:1996 + A1:2002		
0432-CPD-0067		
Substanz...		

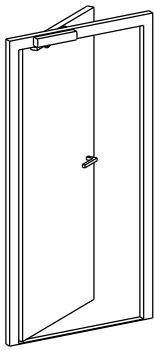

1a

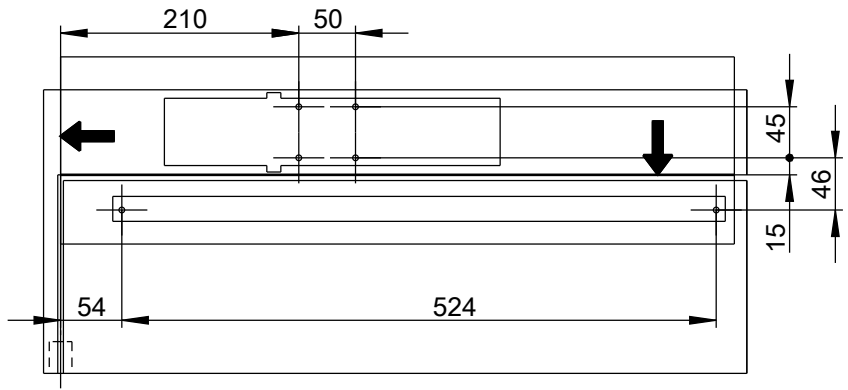

1b

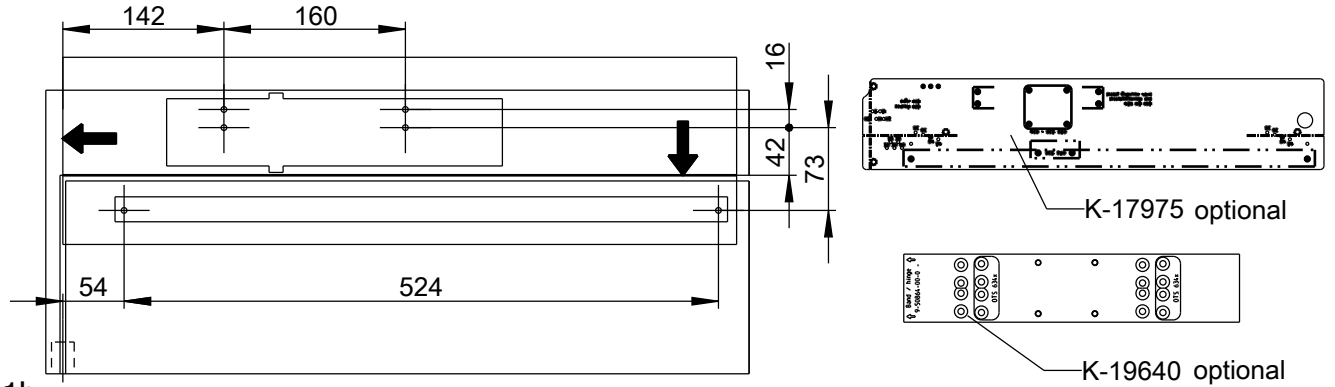

Proprietary rights apply in accordance with ISO 16016.

2

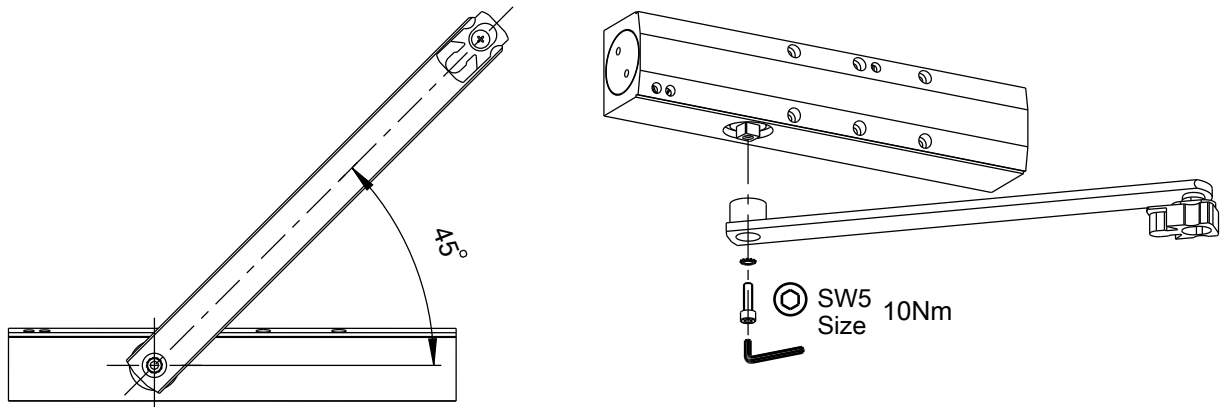

3

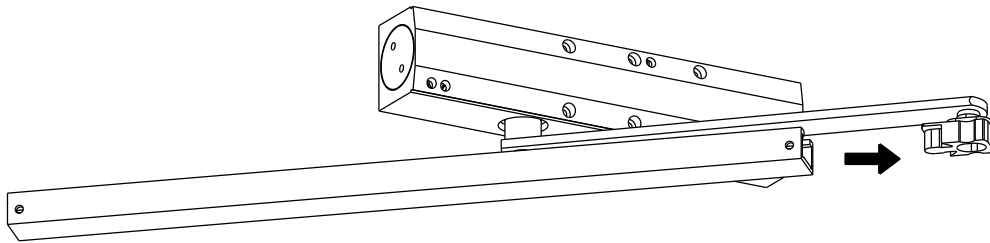

Description

OTS 634 Kopfmontage Bandgegenseite, DIN rechts K-17523

OTS 634 transom mounting on side opposite to hinges, DIN right K-17523

Montageanleitung
assembly instructions
V5



Release No.
--
Mod. No.
G34938

Level	Released	
Ver.	--	Wi
Draft	20.02.2018	Se

Scale
%

Modification
7

Size
4

Drawing No.
0-44860-PL-0-0

Sheet
11/12

Replacement for --

4a

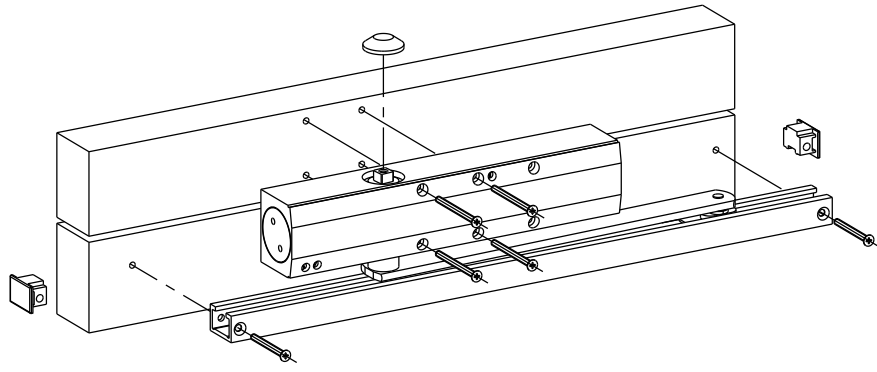

4b

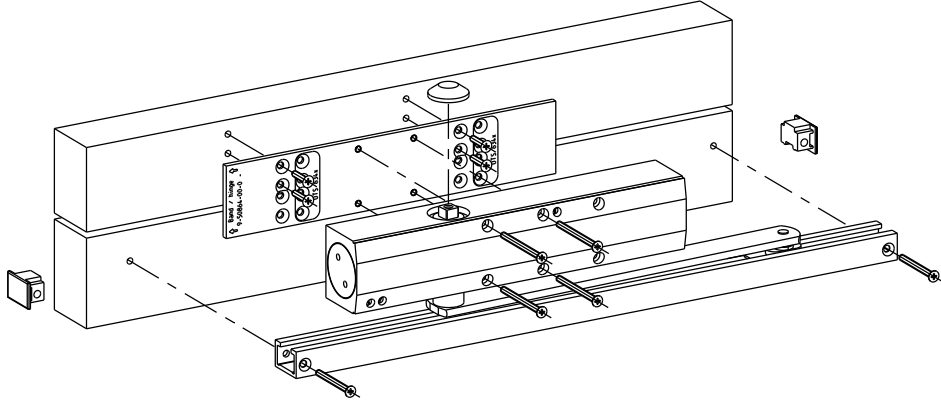

Proprietary rights apply in accordance with ISO 16016.

5

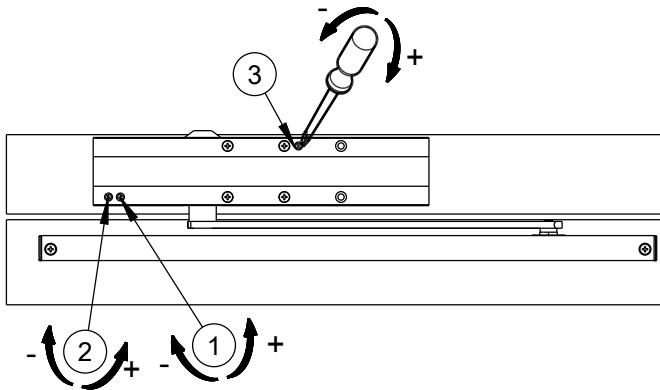

- ① Schließgeschwindigkeit
Closing speed
- ② Türendschlag
Latching force
- ③ Öffnungsdämpfung
Backcheck

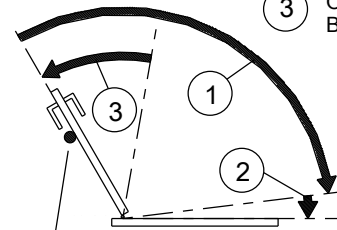

Türstopper bauseits setzen
Door stop to be provided by customer
max. 105°

- EN
- ES
- FR
-
-

6

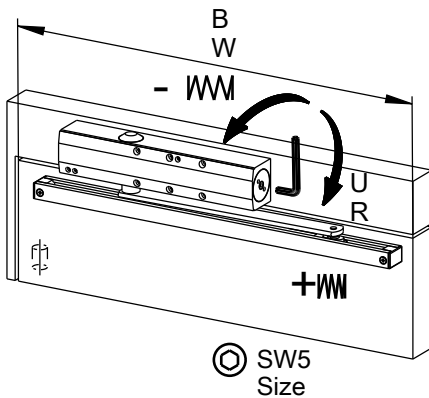

Schließkraft Closing force		
EN	≤ B W	U R
2	850mm	- 10
3	950mm	- 8
4	1100mm	0

7

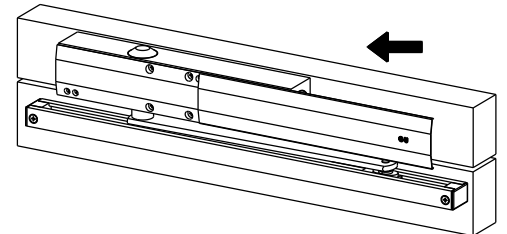

Montageanleitung
assembly instructions
V5

Description

OTS 634 Kopfmontage Bandgegenseite, DIN rechts K-17523

OTS 634 transom mounting on side opposite to hinges, DIN right K-17523



Release No.
--
Mod. No.
G34938

Level	Released	
Ver.	--	Wi
Draft	20.02.2018	Se

Scale
%

Modification
7

Size
4

Drawing No.

Sheet

0-44860-PL-0-0

12/12

Replacement for --